

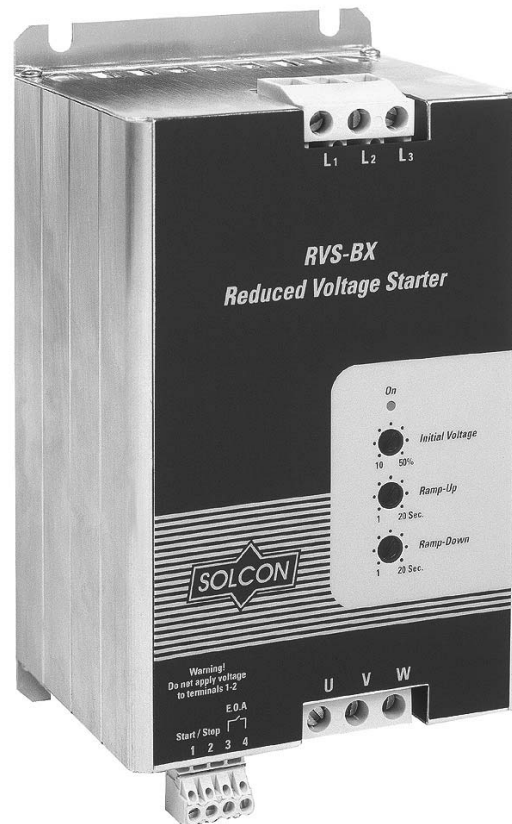

RVS-BX

Compact Soft Starter
8-85A, 220-600V



Instruction Manual

Ver. 1.4.2002

Table of Contents

Page	Subject
3	Starter Selection
4	Installation Notes
5	Wiring
6	Starter Settings
6	Start-up Procedure
7	Dimensions
8	Technical Specification

Safety



- Read this manual carefully before operating the equipment and follow its instructions.
- Installation, operation and maintenance should be in strict accordance with this manual, national codes and good practice. Installation or operation not performed in strict accordance with these instructions will void manufacturer's warranty.
- Disconnect all power inputs before servicing the soft-starter and/or the motor.
- After installation, check and verify that no parts (bolts, washers, etc) have fallen into the starter.

Attention

1. This product was designed and tested for compliance with IEC947-4-2 for class A equipment.
2. The RVS-BX is designed to meet UL, cUL requirements.
3. Use of the product in domestic environments may cause radio interference, in which case the user may be required to employ additional mitigation methods.
4. Utilization category is AC-53a or AC53b. Form1.
5. For further information see Technical Specification.

Warnings



- Internal components and P.C.B's are at Mains potential when the RVS-BX is connected to mains. This voltage is extremely dangerous and may cause death or severe injury if contacted.
- When RVS-BX is connected to Mains, even if start signal has not been issued, full voltage may appear on motor's terminals. Therefore, for isolation purposes it is required to connect an isolating device (C/B, switch, line contactor, etc) upstream to the RVS-BX.
- Starter must be properly grounded to ensure correct operation and safety.
- Check that Power Factor capacitors are not connected to the output side of the soft starter

The company reserves the right to make any improvements or modifications to its products without prior notice.

Starter Selection

The RVS-BX is a Basic Analogue soft starter which incorporates six thyristors to start a three phase squirrel cage induction motor. By supplying a slowly increasing voltage, it provides soft start and smooth stepless acceleration, while drawing the minimum current necessary to start the motor.

A Soft Stop feature can be enabled when the Ramp-Down potentiometer is adjusted. When used, upon stop signal (open contact terminals 1 and 2), motor's voltage is slowly reduced to zero.

Soft-Start Characteristics

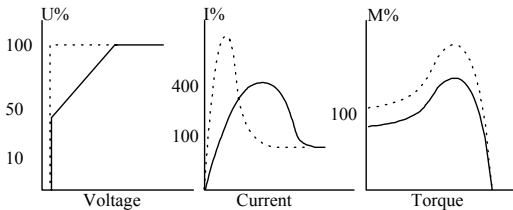

Soft-Stop Characteristics

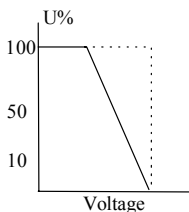

Used for controlled deceleration of pumps and high friction loads.

RVS-BX ratings and Frame sizes

Max. Motor FLA (Amp)	Starter Type FLC(Amp.)	Frame Size
8	RVS-BX 8	B1
17	RVS-BX 17	
31	RVS-BX 31	B2
44	RVS-BX 44	
58	RVS-BX 58	
72	RVS-BX 72	B3
85	RVS-BX 85	B4

Dimensions (mm) & Weights (Kg)

Size	Width	Height	Depth	Weights (Kg)
B1	65	190	114	1.15
B2	120	207	102.5	1.3
B3	129	275	181.5	7.5
B4	129	380	181.5	10.9

The starter should be selected in accordance with the following criteria:

1. Motor Current & Starting Conditions

Select the soft-starter according to motor's Full Load Ampere (FLA) - as indicated on its nameplate (even if the motor will not be fully loaded).

The RVS-BX is designed to operate under the following maximum conditions:

Amb. Temp.	I start	Acc. Time
40° C	300% In	30 Sec
	350% In	20 Sec
	400% In	5 Sec

Max. Starts per Hour : 4 starts per hour at maximum ratings. Up to 10 starts per hour at light load applications.

For higher ratings and/or frequent starts - consult factory with the following information :

- Ambient temperature.
- Actual starting current.
- Actual starting time.
- Time interval between starts
- Load characteristics

Notes: For very frequent starts (inching applications) the inching current should be considered as the Full Load Current (FLC) – consult factory.

2. Mains Voltage

Each starter is factory set for one of the following levels according to the Ordering Information.

Voltage	Tolerance
220- 240 V *	+10 -15 %
380 - 415 V	+10 -15 %
440 V	+10 -15 %
460 - 500 V *	+10 -15 %
575 - 600 V	+10 -15 %

Frequency: 50 / 60 Hz.

* See drawing below for on site voltage modification

Starter's rated 460-500VAC can be field modified for system voltage of 220-240VAC, by placing the internal jumper J3 as shown below. (View when top cover is removed)

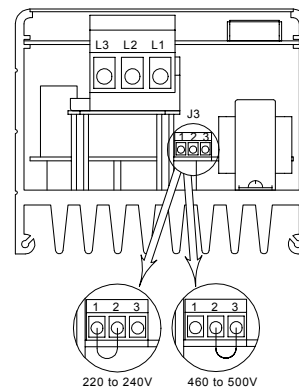

Installation Notes

1. Prior to Installation

Check that Motor's Full Load Ampere (FLA) is lower than or equal to starters Full Load Current (FLC) and that Mains voltage is as indicated on the front panel.

2. Mounting

- The soft starter must be mounted vertically. Allow sufficient space above and below the starter for suitable airflow.
- It is recommended to mount the starter directly on the rear metal plate of the switchgear for better heat dissipation.
- Do not mount the starter near heat sources.
- Protect the starter from dust and corrosive atmospheres.

3. Temperature Range and Heat Dissipation

The starter is rated to operate over a temperature range of -10°C (14°F) to $+40^{\circ}\text{C}$ (104°F).

Relative non-condensed humidity inside the enclosure should not exceed 93%.

As the thyristors are bypassed after the end of acceleration, the heat dissipation during continuous operation is Approx. $0.4 \times I_n$ (in watts).

Example: When motor's current is 30 Amp, heat dissipation will be approx. 12 watts.

Internal enclosure heating can be reduced through the use of additional ventilation.

4. Transient Protection

Voltage spikes can cause malfunction of the starter and damage the SCRs. When expected, use suitable protection such as Metal Oxide Varistors (consult factory for further details).

5. Power Connections

Line voltage must be connected to terminals L1, L2 and L3. Motor must be connected to terminals U, V and W. Do not interchange line and load terminals as damage could occur to the equipment.

Warning

Do not connect any voltage to the control terminals 1 and 2.

6. Overload and Short Circuit Protection

The RVS-BX should be protected against a short circuit by Thyristor Protection fuses.

The recommended $I^2 t$ values are:

RVS-BX type	$I^2 t$
RVS-BX 8	400
RVS-BX 17	2000
RVS-BX 31	3000
RVS-BX 44	6000
RVS-BX 58	12000
RVS-BX 72	18000
RVS-BX 85	?????

Caution

Power factor correction capacitors must not be installed on starter's Load side. When required, Install capacitors on the Line side.

Warning

When Mains voltage is connected to the starter, even if start signal has not been initiated, full voltage may appear on the starter's load terminals. Therefore, for isolation purposes it is required to connect an isolating device (C/B, switch, line contactor, etc) upstream to the RVS-BX (on the Line Side).

Built-in Bypass

The RVS-BX incorporates internal bypass relays allowing current flow through the thyristors only during starting process. At the end of the starting process the built-in relays bypass the thyristors and carry the current to the Motor.

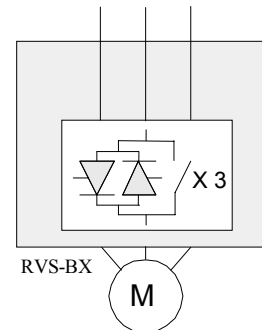

Upon stop signal, or in case of fault, all three bypass relays will open and stop the motor.

When Ramp-Down potentiometer is set to allow soft-Stop process, upon stop command, the bypass relays will open immediately and the current will flow through the thyristors. The voltage will then be reduced slowly and smoothly to zero.

Wiring

Block and Connection Diagram

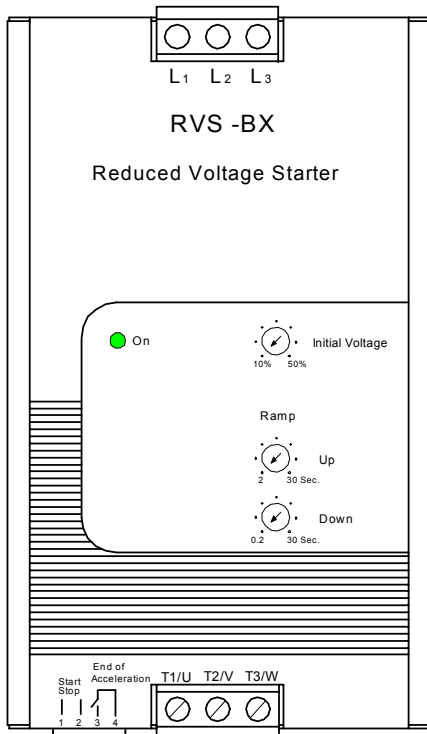

NOTE: The RVS-BX incorporates an internal control voltage transformer connected to phases L1&L3, in case of phase loss of L1 or L3 the starter will stop the motor.

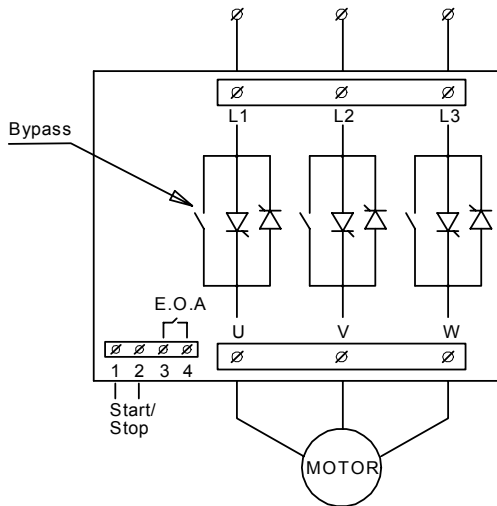

Stop / Start Terminals 1 - 2
 By voltage free contact (Dry contact)
 Close: Start command.
 Open : Stop command.

Warning
Do not apply voltage to terminals 1 - 2.

End of Acceleration (E.O.A) Terminals 3 - 4
 Voltage free, N.O., 8A / 250VAC, 2000VA max.,
 The contact closes after the time adjusted on the "Ramp-Up" potentiometer. The contact returns to its original position on stop signal, on fault condition, upon voltage outage and at the end of Soft Stop.

Use of E.O.A. Contact

This contact can be used for applications such as:

- Activating a valve after a compressor has reached full speed
- Loading a conveyor after the motor has reached full speed.

Warning

Start/Stop with a maintained contact !
 When the line contactor is operated by a maintained contact, in case of Mains failure, the motor will be automatically restarted upon voltage restoration.
 When resetting after a fault with the Reset button, the motor will restart upon fault reset.
 It is therefore recommended not to connect the fault relay to the line contactor.

Connection Diagram

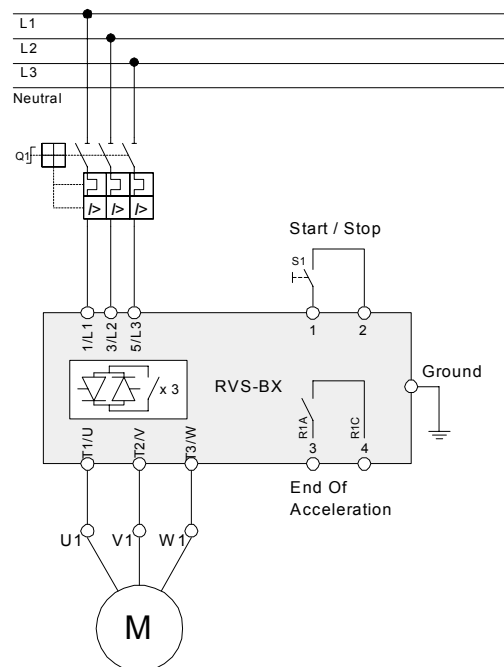

Starter Settings and Startup Procedure

Front Panel Layout

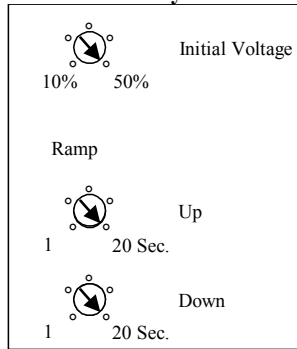

Initial Voltage

Determines the initial voltage to the motor (The torque is directly proportional to the square of the voltage).

Range : 10-50% of nominal voltage.

This adjustment also determines the inrush current and mechanical shock.

Too high of a setting may cause high initial mechanical shock and high inrush current (even if Current Limit is set low, as the Initial Voltage setting over-rides the Current Limit setting).

Too low of a setting may result in prolonged time until motor starts revolving. The motor should start revolving immediately after Start signal.

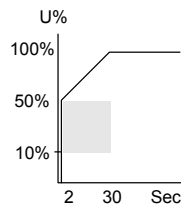

Ramp-up Time

Determines motor's voltage ramp-up time from initial to full voltage.

Range: 1-20 sec.

It is recommended to set Ramp-Up Time to the minimum acceptable value (approx. 5 Sec).

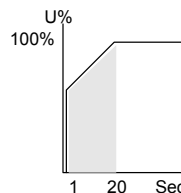

Note: When motor reaches full speed before voltage reaches nominal, Ramp-Up Time adjustment is overridden, causing voltage to quickly ramp up to nominal.

Ramp-Down time (Soft-stop)

Used to control deceleration of high friction loads. When Ramp-Down potentiometer is set, upon stop signal the starter output voltage is gradually ramped down.

Range: 1-20 sec. When "Ramp-down Time" is set to minimum, the E.O.A relay will change position and the motor will stop immediately.

Startup Procedure

- Set front panel potentiometers as follows:
 - Initial voltage to 30%.
 - Ramp Up Time to 5 sec.
- Install a clamp-type ammeter on one of the lines.
- Connect mains voltage to RVS-BX line terminals. The ON LED will light up
- Connect control terminals 1-2. The ammeter will show current flow. If motor starts rotating and accelerates to full speed proceed to Para. 6. If not, increase Starting voltage setting until motor starts rotating shortly after start signal. In case the initial inrush current and mechanical shock are too high, decrease Starting Torque setting and proceed to Para.6.
- Open contact between terminals 1 and 2 to soft Stop and wait until motor stops.
- Close contact between terminals 1 and 2 to Start again and see that acceleration process to full speed is as required.
- If acceleration time is too short, increase ramp up time setting.

Note:

The "ON" LED on the front panel will light up only upon receipt of main voltage at terminals L1, L2 and L3.

Example of Starting Curve

Light loads such as Pumps, Fans, Etc.

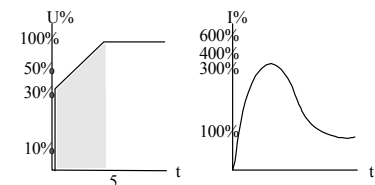

The voltage will quickly increase to the Starting Torque value and then gradually ramp-up to nominal voltage. Simultaneously, the current will smoothly increase to reach peak current value, before smoothly decreasing to the operating current. The motor will steplessly accelerate to full speed.

Note:

In general the starting time is less than the ramp up time and depends on the load characteristics and not on the ramp up time potentiometer.

Dimensions & Weights

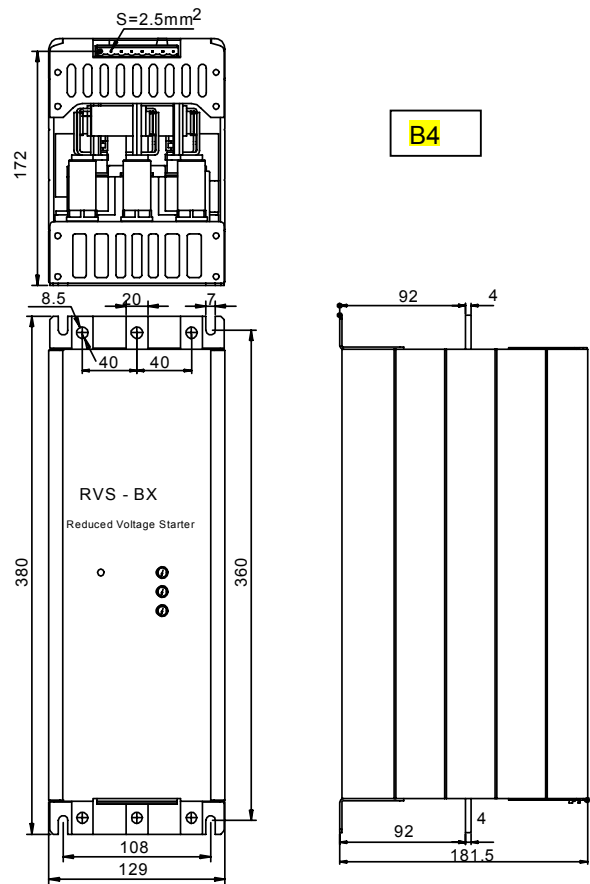
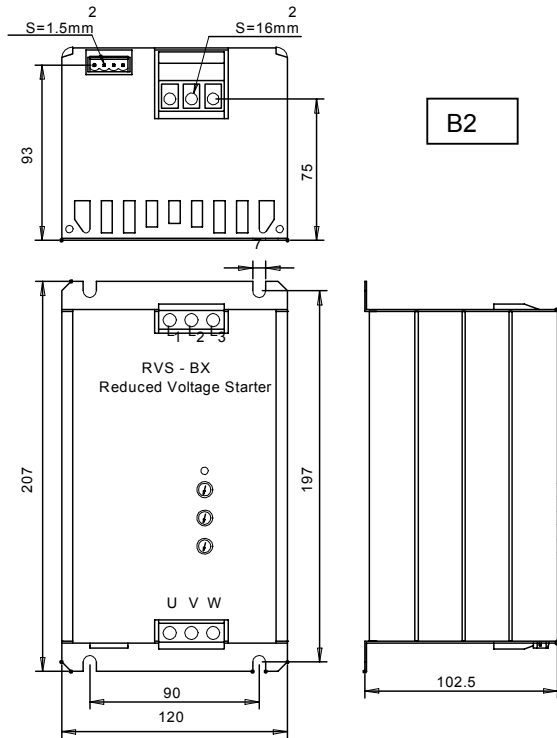
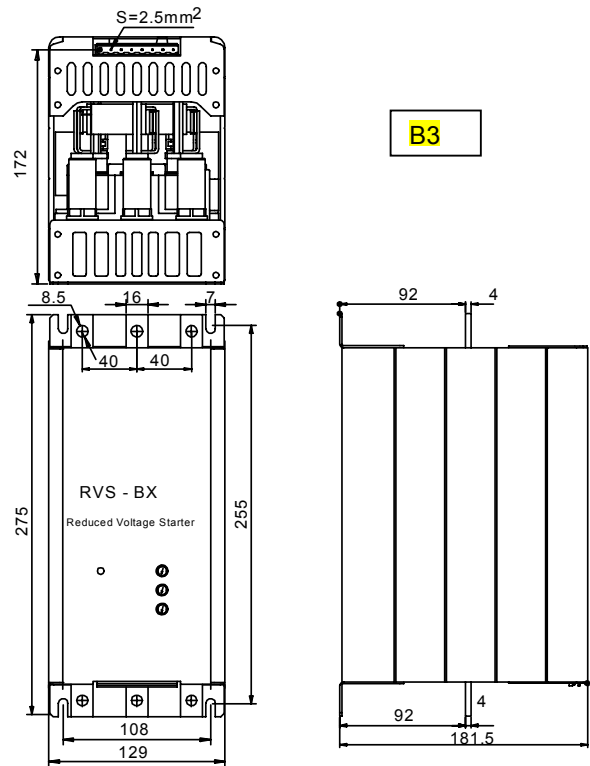
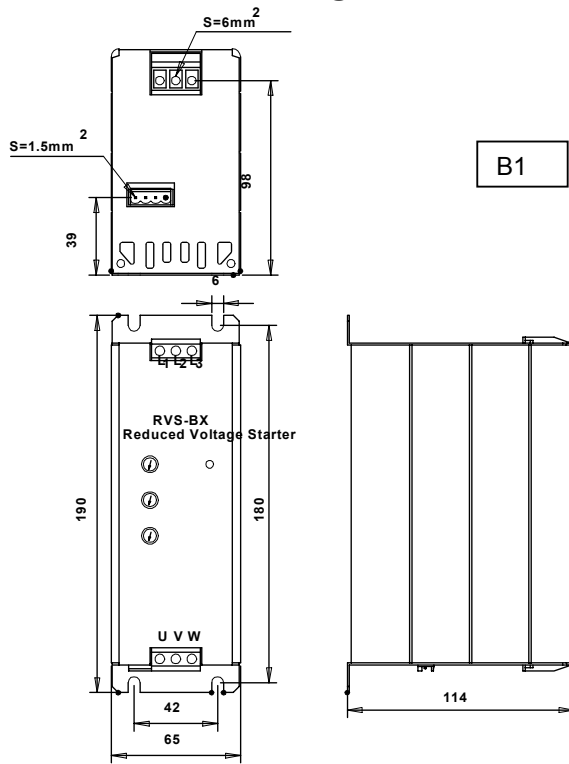

Power & Control Connections

Starter Type In Ampere	Size	Power Connections	Control Connections
RVS-BX 8	B1	Terminals 16 mm ²	Terminals 1.5 mm ²
RVS-BX 17			
RVS-BX 31			
RVS-BX 44			
RVS-BX 58			
RVS-BX 72	B3	Bus-Bars 15mm x 3mm	
RVS-BX 85	B4	Bus-Bars 20mm x 4mm	

Technical Specification

Environment		
Supply voltage	Three phase, line to line, 220 – 240 Vac +10% -15% * 380 – 415 Vac +10% -15% 460 – 500 Vac +10% -15% * 575 – 600 Vac +10% -15%	* 460 – 500 Vac is applicable for 220 – 240 Vac by change position of an internal jumper – J3. As shown in page 3.
Frequency	50 / 60 Hz	
Load	Three-Phase, Three-Wire, Squirrel Cage Induction Motor	
Degree of protection	IP 20	
Altitude	1000 M above sea level	Consult factory for derating above 1000 Meters
Adjustments		
Starting Torque (Initial Voltage)	10-50 % of full voltage	
Ramp Up Time (soft start)	1 - 20 sec.	
Ramp Down Time (Soft Stop)	0.1 - 20 sec.	
Control		
Indication light(LED)	ON - Green	Lights when three phases are connected to the RVS-BX.
Temperatures		
Operating	-10° to 40°C	
Storage	-20° to 70°C	
Relative humidity	93 % - non condensed	
EMC		
Immunity to radio-electric interference	EN 1000-4-3 level 3	Conforming to EN 60947-4-2
Electrostatic discharge	EN 1000-4-2 level 3	Conforming to EN 60947-4-2
Immunity to electrical transients	EN 1000-4-4 level 4	Conforming to EN 60947-4-2
Shock waves of voltage / current	EN 1000-4-5 level 3	Conforming to EN 60947-4-2
Radiated and conducted emissions	EN 1000-4-6 level 3	
Radio frequency emissions	According to EN 55011 class A	Conforming to EN 60947-4-2
Mechanical		
Shock resistance	8 gn	Conforming to EN 60947-4-2
Vibration resistance	2 gn	Conforming to EN 60947-4-2
Output relay		
End of Acceleration Contact	N.O.	
Rated operating current	5 A, 250 V - Size B1 8 A, 250 V – Size B2-B4	